

Tronics

for guitar and three delays

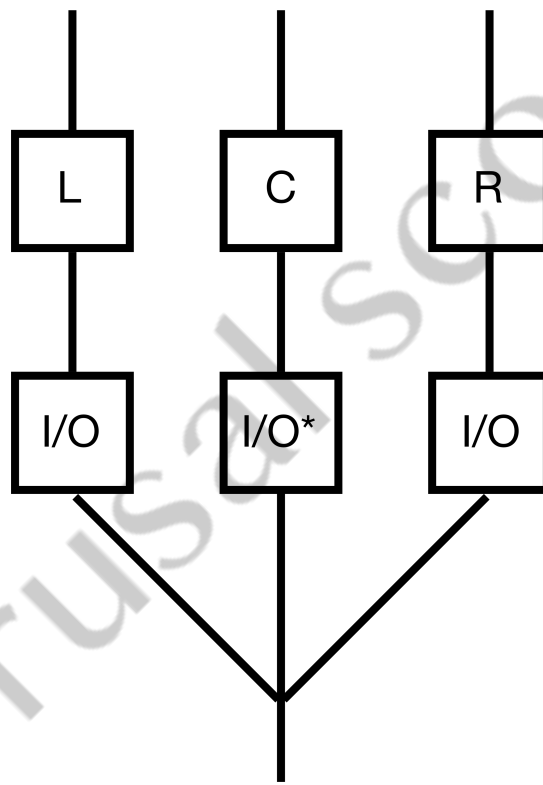

A meditation by
Ryann Daisy Swimmer

Tronics

for guitar and three delays

Performance notes:

Equipment:

The setup should resemble the cover image*

[I/O*] = volume pedal (center channel uses volume swells)

[I/O] = A/B/Y pedal (alternately, using FX pedals at 0 volume has the same effect.)

[L] = Left delay

[C] = Center delay

[R] = Right delay

*this setup could be replicated in a DAW

Delay settings:

Left = 900ms ~65 bpm (tempo L)

Center = 800ms ~75 bpm (tempo C)

Right = 1300ms ~46 bpm (tempo R)

Decay length 20-30 seconds

Tempos are approximations.

Feel free to choose different tempo/delay settings that fall under a similar ratio if desired.

Rehearsal marks designate scenes. Improvisation is free to take place between scene designations. Ornamentation of existing parts is encouraged.

Tronics

for guitar and pedalboard

Ryann Daisy Swimmer

A

Guitar (L,R,C)

mf

Left

mp

Center

mp

Right

p

Steady pulse (tempo L)

Right

Center

Left

n

mp

n

p

mf

n

p

Musical score for section A. It features three staves: Left, Right, and Center. The Left and Right staves each contain a whole note chord with a dynamic marking of *p*. The Center staff contains a whole note chord with a dynamic marking of *p*. Lines connect the chords from the Left and Right staves to the Center staff. The final measure of the Center staff has a dynamic marking of *pp*.

B

Steady pulse (*tempo C*)

Musical score for section B. It features a single staff labeled Center. The score consists of a steady pulse of eighth notes. The first measure is marked with a dynamic of *mp*. The final measure is marked with a dynamic of *p* and includes the instruction "3-4 times".

C

In time (*tempo R*)

Musical score for section C. It features three staves: Left, Right, and Center. The Left staff contains a half note with a dynamic of *p*. The Right staff contains a half note with a dynamic of *mp*. The Center and Left staves (on the right side of the score) contain a half note with a dynamic of *p*. Lines connect the chords from the Left and Right staves to the Center and Left staves. The tempo is marked as (*tempo R*).

D

In time (*tempo L*)

Musical score for section D. It features three staves: Left, Right, and Center. The Left staff contains a half note with a dynamic of *p*. The Right staff contains a half note with a dynamic of *mp*. The Center staff contains a half note with a dynamic of *mp*. Lines connect the chords from the Left and Right staves to the Center staff. The tempo is marked as (*tempo C*).

E

Steady pulse (*tempo C*)

Center



Center



Center



F

Right

Center

Left